

## Branchevejledning

# Arbejde i tunneler med diameter under 2 meter



**Sikring af Arbejds miljø**  
ved Pipe Jacking med særlig fokus på ergonomi og beredskab

## Indhold

<b>1</b>	<b>Formål og baggrund</b>	<b>3</b>
<b>2</b>	<b>Ergonomi ved arbejde og færdsel i tunneler og TBM</b>	<b>4</b>
2.1	Arbejdstid i tunnel og TBM	4
2.2	Persontransport i tunnel	4
2.3	Indretning af TBM	5
2.4	Tilsyn	6
2.5	Materieltransport	6
2.6	Reparations- og vedligeholdelsesarbejder	7
2.7	Udskiftning af skæreværktøjer i borehoved (interventions)	7
2.8	Vedligehold af grave-/fræseværktøj (åben front)	8
2.9	Fjernelse af forhindringer fra gravefront (åben front)	8
2.10	Demontering af mellempressestationer	9
2.11	Demontering af booster-pumper	9
2.12	Rydning af tunnel	9
2.13	Injicering af overcut	9
<b>3</b>	<b>Uheld og ulykker</b>	<b>10</b>
3.1	Beredskab – flugt og evakuering	10
3.2	Indskridning af jord (åben front)	10
3.3	Ildebefindende i forbindelse med arbejde i tunnelen	10
3.4	Ildebefindende i forbindelse med alene arbejde på TBM (fx. boreoperatør)	11
3.5	Passage af booster-pumpe eller andre forhindringer med bære	11
3.6	Passage af mellempressestationer med bære	11
3.7	Passage af jordvogn med bære	12
3.8	Brand i tunnel	12
3.9	Brand på TBM	13
<b>4</b>	<b>Tunneleringsmetoder</b>	<b>14</b>
4.1	Almindelige arbejdsoperationer	14
4.2	Ergonomi i tunnel og TBM:	15
4.3	Beredskab og evakuering fra tunnel og TBM:	16
	<b>Appendix 1 – Machine operations</b>	<b>17</b>

# Formål og baggrund ...

## 1 Formål og baggrund

Denne vejledning er målrettet for tunneler med indvendig diameter fra Ø1200 - Ø1800, hvor der i perioder er behov for mandskab i tunnelen under etableringen.

Initiativet til vejledningen er taget på baggrund af påbud fra Arbejdstilsynet til et projekt, hvor der var projekteret med Ø1600 og Ø1800 tunneler. Påbuddet blev givet, på baggrund af utilstrækkelig dokumentation af hensigtsmæssige ergonomiske arbejdsstillinger samt dokumentation af flugt og evakueringsveje ud af tunnelen.

Mange af de beskrevne anbefalinger i denne vejledning, indgik i efterkommelsen af Arbejdstilsynets påbud.

Denne branchevejledning er udarbejdet af en arbejdsgruppe i samarbejde mellem No Dig Infra og Dansk Forening for Tunnel og Undergrundsarbejder, DFTU. Arbejdsgruppen bestod af repræsentanter for både Bygherre, rådgiver og entreprenør.

Formålet har været at etablere en fælles referenceramme i branchen samt en fælles forståelse for nogle af de udfordringer, der kan opstå ved arbejde i mindre tunneler.

Branchevejledningen er udarbejdet, som en vejledning for branchens aktører med anvisninger til, hvordan det er muligt at udføre tunneler i dimensioner med indvendige diametre fra Ø1200 - Ø1800. Vejledningen indeholder ikke en fuldstændig liste over krav og udførelsesmetoder, men anviser forslag til, hvordan det er muligt at sikre en god ergonomi samt sikre flugt- og evakueringsveje ved arbejder i tunnelen.

I forbindelse med denne branchevejledning er der også udarbejdet et særskilt dokument, benævnt 'Machine Operations', som detaljeret beskriver de enkelte arbejdsopgaver for hver arbejdsopgave, som branchevejledningen omhandler. Formålet med dokumentet 'Machine Operations' er tofoldigt: For det første at tydeliggøre, hvordan de forskellige operationer kan udføres under hensyntagen til arbejdsmiljø og Best practice, for det andet at bekræfte, at de anbefalinger og retningslinjer, der præsenteres i branchevejledningen, er praktisk gennemførlige.

Med venlig hilsen

Jens T. Rasmussen,  
HOFOR A/S

Mads Abrahamsen,  
Rambøll Danmark

Poul-Erik Christensen,  
Entreprenørfirmaet Østergaard A/S

Morten R. Nielsen,  
Entreprenørfirmaet Østergaard A/S

Martin W. Vede,  
COWI A/S

## 2 Ergonomi ved arbejde og færdsel i tunneler og TBM

Ved tunnelstørrelser hvor personer i tunnelen ikke kan færdes oprejst skal der allerede i projekteringsfasen tages stilling til hvordan personer og øvrige transportere kan udføres forsvarligt. Da tunnelen både er en adgangs- og flugtvej, accepteres det ikke at der projekteres med foroverbøjet gang, da det er en unødigt ergonomisk belastning for den enkelte person.

Arbejdsstillinger i tunnelen vil i størstedelen af tiden være uhensigtsmæssige, da et eller flere af kroppens led er i unormal eller anstrengende position. Dette kan fx. være arbejde over hovedhøjde, under knæhøjde, med udstrakte arme, knæliggende, hugsiddende, med foroverbøjet ryg osv. Derfor er det særlig vigtigt i de små tunneler at sikre at medarbejderne kan udføre arbejdet på den mest hensigtsmæssige måde herunder brug af relevante egnede tekniske hjælpemidler hvor det er muligt.

### 2.1 Arbejdstid i tunnel og TBM

Grundet den lave ståhøjde, er det fra arbejdstilsynets side påkrævet at arbejdstiden reduceres til maksimalt 4 timer pr. dag pr person.

De 4 timer gælder for alt arbejde, ophold og færdsel i tunnel og TBM inkl. transport til og fra arbejdsstedet i tunnelen. Dvs. at selvom operatøren/piloten sidder i en god arbejdsstilling ved styrepulten på TBM, gælder de 4 timer stadig.

Når en medarbejder sammenlagt over en arbejdsdag har været 4 timer inden i tunnel og/eller TBM, kan medarbejderen godt udfylde resten af arbejdsdagen med andre opgaver på byggepladsen, såfremt der er fuld ståhøjde.

### 2.2 Persontransport i tunnel

Transport i tunnelen må som tidligere beskrevet ikke udføres foroverbøjet over længere distancer. Det er acceptabelt at krydse forhindringer foroverbøjet, såfremt den primære transportvej kan tilbagelægges i en ergonomisk afslappet stilling, dvs. uden foroverbøjet gang.

Der bør derfor anvendes elektriske køretøjer, til persontransport, hvor personen sidder i en forholdsvis afslappet stilling.

I valg af el-køretøj til tunnelen, skal der tages hensyn til, at det skal være nemt at vende kørselsretningen på køretøjet, enten ved fysisk at vende køretøjet eller ved at vende betjeningspanel og sæde. Bakning anses ikke som en ændring af kørselsretningen, idet det medfører andre unødige belastninger og risici.

Det giver først mening at anvende et køretøj, når tunnelen har en rimelig længde, så håndteringen af køretøjet ikke overskygger belastningen ved den tilbagelagte

Figur 1: Person el- køretøj



# Ergonomi ved arbejde og færdsel i tunneler og TBM ...

Figur 2: Skinne monteret i toppen af tunnel, som køretøj kan ophænges i.

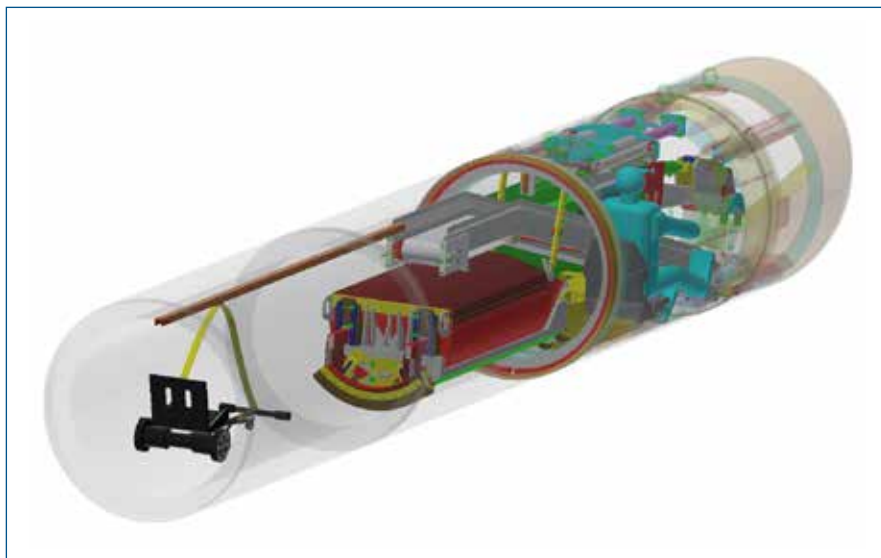

strækning. Det vil derfor være en samlet vurdering af afstand og tunneldiameter, der begrunder om det giver værdi.

Det anbefales, at der altid anvendes elektriske køretøjer ved distancer længere end:

- Ø1200: 25 meter
- Ø1400: 25 meter
- Ø1600: 30 meter
- Ø1800: 40 meter

Umiddelbart før styrepult/arbejdsplads på TBM, skal der indrettes et område til at vende og parkere køretøjet uden at være til gene for arbejdet i tunnelen. Dette kan fx være ved at hænge køretøjet op på væggen eller i en skinne monteret i toppen af tunnelen.

Skal der udføres arbejde af 2 personer i tunnelen samtidig, skal der ligeledes benyttes 2 køretøjer og der skal være plads til at vende og opbevare dem begge.

Af hensyn til brandfare, bør opladning af elektriske køretøjer så vidt muligt foregå uden for tunnelen. Er det nødvendigt at oplade batterier inde i tunnelen, bør dette foregå, når der ikke er personer i tunnelen. Opladningsstation placeres altid så den ikke er mellem medarbejder og udgang, og dermed ved brand kan blokere flugtvejen ud af tunnelen.

Ved længere strækninger, hvor der kræves en slurry booster-pumpe midt på strækket, vil det kræve, at der placeres et personkøretøj på hver side af pumpen. Herudover skal der laves en udformning, hvor personale kan passere booster-pumpen på forsvarlig måde, samt en procedure for båreredning af en tilskadekommen. Hvis dette kræver hjælpeudstyr, skal dette placeres på stedet klar til brug.

## 2.3 Indretning af TBM

For at arbejdsmiljøet kan forbedres under udførelsen, anbefales det, at der bag TBM installeres stål-efterløberrør. Det betyder, at persontransport forbi evt. transportbånd, jordvogn, transformator og andet udstyr, kan foretages på en forsvarlig måde. Den øgede

# Ergonomi ved arbejde og færdsel i tunneler og TBM ...

Figur 3: Stål efterløbsrør (servicerør) for at øge den indvendige diameter.

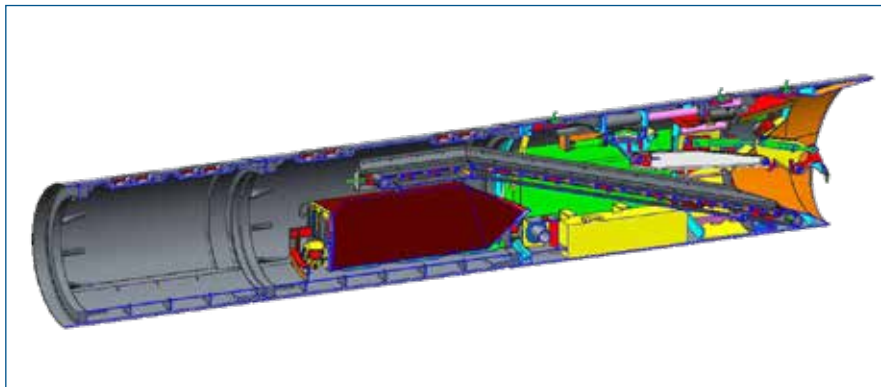

Figur 4: Transportvogn for mindre udstyr

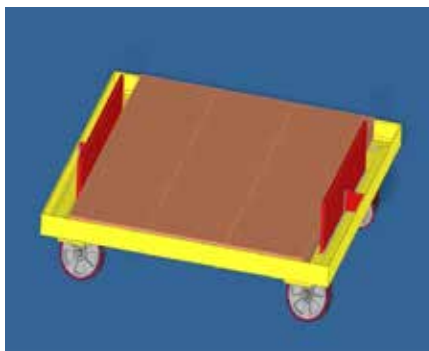

Figur 5: Løfte udstyr designet til tunnel dimension

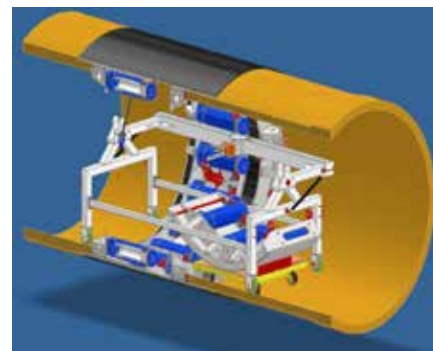

"rum diameter" betyder samtidig, at div. værktøj og reservedele kan lægges i depot umiddelbart bag TBM'en inden opstart på tunnelering, og samtidig skabes der bedre pladsforhold for medarbejderne, der skal opholde sig og færdes i området.

## 2.4 Tilsyn

For at minimere den fysiske tilstedeværelse på TBM og i tunnel, bør der opsættes kamera (billede/lyd) på alle steder i tunnelen, hvor der normalt vil være behov for dagligt tilsyn. Kameraernes formål er udelukkende at begrænse den fysiske færdsel og ophold i tunnelen. Hvert kamera overvåges fra terræn, så tilsynet føres derfra og ikke i selve tunnelen.

Eksempler på placering af kamera:

- Gennem hele tunnellen, ved kritiske installationer, der erfaringsmæssigt kan lække eller have nedbrud.
- Ved hver mellempressestation, således at cylindrene, fleksible slanger og overkørselsplader kan tilses.
- I overgangen fra tunnel til TBM ved alle slanger, rør og kabler.
- Ved pilot/operatør i TBM (særlig relevant, hvis det er alenearbejde)
- Trykkammer

# Ergonomi ved arbejde og færdsel i tunneler og TBM ...

Foto 1: Fjernstyret el-vogn til transport kan anvendes til materiale



## 2.5 Materieltransport

For alt transport af materiel i tunnel, fx elkabler, slurryrør, luftrør, bentonitrør, skal der anvendes vogne og løfteudstyr, der er designet til de aktuelle dimensioner og opgaver. Ligeledes er det nødvendigt at have en specialvogn og løfteudstyr ved demontering af fx mellempressestationer.

Ved transport af tunge emner i tunnelen kan der anvendes en mobil el-lift, der kan flytte emnerne og løfte dem til den ønskede højde.

Ved anvendelse af mobil el-lift vil personkøretøj kunne hænges op i stålefterløbsrør under tunnelering, derved er den klar når personale skal retur igen. Se foto 1.

## 2.6 Reparations- og vedligeholdelsesarbejder

For at minimere arbejdsbyrden for reparations- og vedligeholdelsesarbejde, bør entreprenøren anvende fuldt renoveret eller nyt udstyr, der inkluderer alle backup-systemer og installationer i tunnelen.

Ved reparation og vedligehold af større materiel skal der være en plan for, hvordan komponenten kan tages ud af tunnelen og repareres i skakten for derefter at blive kørt ind i tunnelen og monteres igen, så større arbejder ikke skal foregå i tunnelen. Ved alt reparations, vedligeholdelsesarbejde og fjernelse af hindringer i borefronten, på TBM eller i selve tunnelen, bør der være minimum 2 personer til stede.

## 2.7 Udskiftning af skæreværktøjer i borehoved (interventions)

Af ergonomiske årsager bør transport af skæreværktøj igennem tunnelen holdes på et minimum. Derfor skal skæreværktøj, der forventes at blive udskiftet under tunneleringen, placeres dels på TBM og dels umiddelbart bag ved TBM inden tunneleringen påbegyndes.

Udskiftet skæreværktøj bør ligeledes opbevares på TBM og lige bag ved TBM og fjernes først, når tunnelmaskinen ankommer til modtageskakten.

Håndtering af skæreværktøjer på TBM skal ligeledes planlægges, så de ikke håndteres manuelt. Brug af fx. slisker eller taljer ophængt i toppen af tunnelen anbefales.

# Ergonomi ved arbejde og færdsel i tunneler og TBM ...

▶ Sliske til skæreskive igennem trykkammer

▶▶ Eksempel på løbekat over forhindringer i tunnel.



## 2.8 Vedligehold af grave-/fræseværktøj (åben front)

Vedligehold af grave-/fræseværktøj ved åben front tunnelering anbefales udført i områder, hvor borefronten er stabil, og hvor der ikke er konstateret vandindtrængning. Skjoldet presses i denne forbindelse så langt frem som muligt for at sikre fronten bedst muligt. Før personale går frem til gravefronten skal det sikres, at den er stabil ved at grave skjold er presset maksimalt frem og der ikke er afgraved mere jord væk end nødvendigt. Da arbejdet typisk sker siddende på knæ, skal arbejdet planlægges med arbejdsperioder, der passer til arbejdets art (eventuelt med flere hold af hensyn til arbejdstiden).

## 2.9 Fjernelse af forhindringer fra gravefront (åben front)

Forhindringer der ikke kan fjernes med gravearm eller fræser ved åben front tunnelering fjernes manuelt. Dette kan f.eks. være spaltning af større sten, fjernelse af krydsende ledninger, eller fjernelse af konstruktioner, der er efterladt i jorden. Før personale går frem til gravefronten skal det sikres, at den er stabil ved at grave skjold er presset maksimalt frem, og der ikke er afgraved mere jord væk end nødvendigt. Da arbejdet typisk sker siddende på knæ, skal arbejdet planlægges med arbejdsperioder, der passer til arbejdets art (eventuelt med flere hold).

# Ergonomi ved arbejde og færdsel i tunneler og TBM ...

## 2.10 Demontering af mellempressestationer

Arbejdet skal planlægges, så det ikke på noget tidspunkt bliver nødvendigt at håndtere stemplerne manuelt.

De nedre stempler kan løftes op med talje fastgjort i toppen af tunnelen. De øvre stempler kan demonteres vha. af talje i toppen og sænkes direkte ned på en transportvogn. Det skal sikres, at stemplerne ikke svinger sideværts, når de frigøres.

Stemplerne placeres på en transportvogn, der køres ud af tunnelen til skakten.

## 2.11 Demontering af booster-pumper

Boosterpumper skal kunne demonteres, så arbejdet i selve tunnelen reduceres til et minimum. Boosterpumper bør være på hjul, så de kan trækkes ud af tunnelen ved brug af fx. wirespil.

## 2.12 Rydning af tunnel

Håndteres kablerne med håndkraft skal tunge kabler være inddelt i sektioner, f.eks. 3-5m, så krav til manuel håndtering kan overholdes. Kablerne tages ned fra hylderne og skal kunne placeres direkte på en vogn, som transporterer udstyret ud af tunnelen.

Ved nedtagning af tunge emner, der ikke må håndteres manuelt, skal der anvendes løfteudstyr. Der er primært 2 forskellige former for løfteudstyr som kan anvendes i de mindre tunneller.

Kædetalje: En kædetalje kan monteres i top tunnelrør, ved hjælp af indboring af et anker med indvendigt gevind, i dette gevind indsættes en ringskrue hvori kædetaljen monteres. Kædetaljen kan nu løfte diverse rør og slanger ned fra hylderne.

Kran: Der kan indkøbes en specialfremstillet kran, der kan tilpasses den aktuelle tunnel diameter. Kranen vil skulle være godkendt til montering på f.eks. et køretøj, hvis den ikke allerede er monteret på hjul. Kranen monteres på køretøjet og kan løfte emnerne ned og lægge dem på tilhørende vogn, der kan køres ud til skakten.

## 2.13 Injicering af overcut

Injicering omkring rørene kan udføres med manuelle eller automatiske ventiler. Under tunnelering anvendes disse til injicering af bentonit, efter endt tunnelering anvendes de til efterinjicering. Før efterinjektion skal automatiske ventiler erstattes af manuelle. Ved manuel injicering, manuel åbning og lukning af ventilerne, bør der anvendes køretøj til færdslen i tunnelen, da der ikke er fuld ståhøjde.

Placering af ventiler til injicering skal overvejes i forhold til arbejdsmiljø og udførelse af tunnelen, herunder sikring af at toppen af tunnelen er fuldt efterinjiceret.

Hvis ventilerne placeres kl. 01.00 og kl. 23.00 højnes arbejdsmiljøet ved at tilgode højdene i midten af røret, dette mindsker sandsynligheden for at f.eks. sikkerhedshjelm kolliderer med de tekniske installationer, som tilkobles ventilen.

Den valgte placering skal altid vurderes af entreprenøren ud fra både tekniske og arbejdsmiljømæssige forhold.

## 3 Uheld og ulykker

### 3.1 Beredskab – flugt og evakuering

Arbejde og færdsel i tunneler og på TBM er defineret som særlig farligt arbejde af Arbejdstilsynet. Arbejdet vurderes som særlig farligt, da der er trange arbejdsforhold, der kun er en adgangsvej/flugtvej, det er under terræn og det ofte er alenearbejde.

Særlig farligt arbejde skal altid risikovurderes før det udføres og medarbejdere skal have en grundig og fyldestgørende instruktion til arbejdet.

Før arbejdet påbegyndes, skal der være udarbejdet en beredskabsplan, der beskriver hvordan ulykker i tunnelen håndteres, herunder hvordan personer reddes ud af tunnelen. Denne beredskabsplan skal være kendt af alle relevante personer på byggepladsen.

### 3.2 Indskridning af jord (åben front)

Stabiliteten af tunneleringsfronten sikres generelt med sandhylder, bunden af skjoldet og eventuelt skodder for at kunne lukke mest muligt af fronten af. Ved små diametre er der typisk ikke tilstrækkeligt plads til at etablere skodder.

Det skal sikres, at der ikke opholder sig personer ude i fronten ved mistanke om svigt af stabilitet.

Hvis der træffes ustabile jordlag kan disse skride ind i maskinen og flyde over underkanten og ned af sandhylden. I dette tilfælde skal TBM-piloten forlade sin plads og gå ud af boremaskinen. Hoved- og mellempressestationer skal samtidig presse rørstrengen og TBM'en så langt frem som muligt for at stoppe yderligere jordindfald. Når situationen er stabiliseret, tømmes maskinen for jord, der er flydt forbi skjoldet.

### 3.3 Ildebefindende i forbindelse med arbejde i tunnelen

I forbindelse med udarbejdelse af beredskabsplan for evakuering af personer fra tunnelen, skal de ergonomiske forhold tages i betragtning.

Der skal være en bære på TBM og evt. også i skakten. Båren skal kunne transporteres på en hensigtsmæssig måde igennem tunnelen, fx. ved at båren kan placeres som en anhænger til det elektriske køretøj.

Båren skal ligeledes være egnet til lodret transport, så den tilskadekomne kan hejses op fra skakten/udgravningen.

Foto 4: Tunnelfront med sandhylde og hydrauliske klapper

Foto 5: Tunnelfront med sandhylde



# Uheld og ulykker ...

Figur 6: Forhindringer i tunnel, hvor bære skal transporteres over



### 3.4 Ildebefindende i forbindelse med alene arbejde på TBM (fx. boreoperatør)

Det anbefales at opsætte kameraer flere steder i tunnelen og ved fronten for, udover at minimere tilsyn, sikre at personalet udenfor tunnelen kan holde øje med medarbejderne inden i tunnelen, særligt ved borefronten.

Er der forhindringer midt i tunnelen, kan det være nødvendigt at have en bære og et køretøj på begge sider af forhindringen.

### 3.5 Passage af booster-pumpe eller andre forhindringer med bære

Ved alle forhindringer der måtte være i tunnelen, skal der tages hensyn til hvordan en bæreevakuering kan udføres, dette skal beskrives i beredskabsplanen.

Ved passage af booster-pumper i tunnelen, kan det være nødvendigt at installere en løbekat over pumpen, så båren ved hjælp af løbekatten kan transporteres over. Det vil være særdeles svært at løfte en bære manuelt over en større forhindring i tunnelen, grundet tyngdepunktet på båren sammenholdt med fremkommeligheden.

Monteres der en løbekat over en større forhindring, kan den også anvendes til at få diverse materiel forbi forhindringen, så det ikke er nødvendigt manuelt at løfte nogen emner over f.eks. en booster-pumpe.

Det anbefales herudover, at der ved længere tunnelstrækninger, hvor der kræves en booster-pumpe på strækket, placeres person køretøj(er) på hver side af pumpen. Der skal ligeledes laves en foranstaltning, hvor personale kan passere på forsvarlig måde.

### 3.6 Passage af mellempressestationer med bære

For at lette al transport i tunnelen, skal bunden ved mellempresse stationer udstyres med en overkørselsplade med samme krumning som tunnelrøret. Pladen skal være fastgjort på den ene side af mellempressestationen i tunnelrøret, således pladen hele tiden dækker over niveauspringet ved mellempressestationen. Pladen skal udformes så den er let at køre over.

# Uheld og ulykker ...

Figur 7: Snit af hhv. jordvogn og tunnel med illustration af fremkommelighed forbi vogn

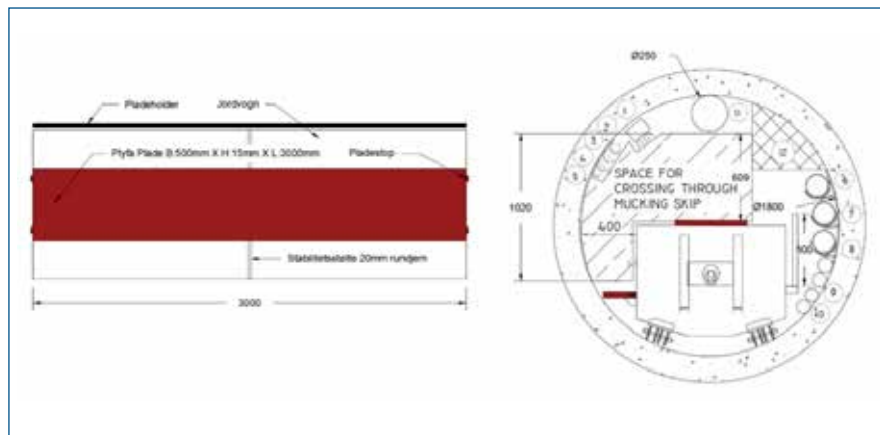

## 3.7 Passage af jordvogn med bære

Jordvogn skal indrettes, så personel kan passere den i tunnelen, for eksempel ved at der anordnes en lille gangbro på siden af vognen. Det kan være nødvendigt med en reduceret højde og/eller bredde på jordvognen, for at gøre det muligt at komme forbi.

Jordvognen bør ligeledes udstyres med plader, der kan lægges over jordvognen, således at en bære med en person kan køres over jordvognen i en evakuerings situation. Pladerne bør være umiddelbart tilgængelige og kan placeres enten på vognen eller umiddelbart uden for tunnelen. Pladerne skal ligge fast på vognen efter montage så de ikke skrider ud undervejs.

Hvis pladerne placeres i skakten fremfor på vognen, skal der være en plan for hvordan de hurtigt og forsvarligt kan transporteres ind til jordvognen.

## 3.8 Brand i tunnel

Grundet de vanskelige flugtveje fra små tunneler, er det vigtigt at sikre, at der er tid til og mulighed for flugt fra tunnel og TBM ud til skakt. Entreprenøren skal altid før opstart af tunnelering lave en beredskabsplan, hvor brand ligeledes indgår.

I tilfælde af brand i tunneler betragtes de tekniske installationer, som forbinder tunnelmaskinen, ikke som en væsentlig brandrisiko, idet de opfylder alle gældende tekniske og sikkerhedsmæssige krav til elektriske installationer. Denne vurdering gælder også for mellempressestationer inde i tunnelen, uanset om disse stationer bliver tryksat fra en hydraulikstation, der er placeret enten i tunnelmaskinen eller i pressegruben.

Såfremt projektets udførelse nødvendiggør installation af en hydraulikstation inde i selve tunnelen for at kunne sikre det nødvendige hydrauliske tryk under driftsforhold, skal denne hydraulikstation især sikres mod brandfare. En sådan sikring kan opnås ved at udstyre hydraulikstationen med termosikringer, der forhindrer overophedning af komponenter, samt etablere et system for realtids-overvågning af udstyrets tilstand. Termosikringen vil således forhindre komponenter i at nå en temperatur, hvor overfladen kan antænde hydraulikolie fra eventuelle beskadigede slanger, mens realtidsmonitoreringen, eksempelvis via videolink til boreoperatør eller kontrolcenter, muliggør en kontinuerlig visuel inspektion af udstyrets funktionsdygtighed og sikkerhedstilstand. Tilsvarende sikkerhedsforanstaltninger

skal implementeres for øvrigt teknisk udstyr, såsom slurry booster pumper, som installeres inden for tunnelens rammer.

Den primære brandrisiko i anlægsfasen anses at forekomme under reparationsarbejde på udstyr placeret inde i tunnelen. I sådanne situationer er det altafgørende, at personale er særligt opmærksomme på operative procedurer ved anvendelsen af potentielt brandfarligt værktøj som vinkelslibere og skærebrændere, især i nærheden af mellemstationer og installerede tekniske anlæg herunder hydraulikstationer og slurry booster pumper. Efter endt reparationsarbejde er det desuden essentielt at sikre, at alle spildte olier fjernes grundigt, ligesom brugte og oliedækkede klude skal bortskaffes på en sikker måde. Dette skyldes risikoen for selvantændelse af olieindsmurte klude under visse omgivelsesforhold, hvilket udgør en væsentlig brandsikkerhedsmæssig udfordring.

For at minimere en brandhændelse kan brandkapsler installeres på nøje udvalgte og kritiske lokationer, hvor der er øget risiko for brand eller brandspredning.

Forholdsregler vedr. opladning og opbevaring af batterier se pkt. 2.2 og 3.9

### 3.9 Brand på TBM

Det er et grundlæggende krav, at temperaturen på alle elmotorer i tunnelmaskinen kontinuerligt overvåges for at forhindre overophedning og derved reducere risikoen for brand og funktionsfejl. Overvågningen kan eksempelvis ske ved anvendelse af termosikringer eller ved integration af funktioner i tunnelmaskinens styringssoftware, som automatisk kan deaktivere motorer ved registreret temperaturoverskridelse.

For at minimere risici for brand, bør det overvejes, om der skal installeres nogle af følgende foranstaltninger:

- Et brandalarmsystem, som automatisk udsender signaler til boreoperatøren i styrecontaineren. I tilfælde hvor tunnelmaskinen styres direkte fra selve maskinen, skal brandalarmen tilkobles, således at både personale i pressegruben og på terræn informeres hurtigt og effektivt om en potentiel brandhændelse.
- Placering af brandslukkere på strategiske steder i hele tunnelmaskinen for at sikre hurtig adgang til slukningsmidler i tilfælde af brand.
- Et brandbekæmpelsessystem bestående af brandsprinklere i toppen af tunnelmaskinen, som er designet til at etablere et vandgardin, som kan begrænse eller slukke en brand i de indledende stadier samt til tilbageholde røg.
- Eventuelle brandkapsler kan installeres på nøje udvalgte og kritiske lokationer, hvor der er øget risiko for brand eller brandspredning.
- Trykflasker, eksempelvis ilt og gasflasker m.m. anvendt under reparationsarbejde i tunnelmaskinen, skal fjernes umiddelbart efter arbejdsopgaverne er afsluttet og inden tunneleringen genoptages. Dette for at mindske risikoen for uheld relateret til brand eller eksplosionsfare.
- Batterier til transportmidler beregnet til persontransport inde i tunnelen skal fjernes fra tunnelmaskinen, før tunnelingen startes op og køres ubemandet. I tilfælde, hvor tunnelmaskinen bemannes, som eksempelvis ved en Earth Pressure Balance (EPB) maskine, kan batterier dog forblive i maskinen samtidig med, at personale befinder sig derinde. Se i øvrigt afsnit 2.2 Persontransport i tunnel.

# Tunneleringsmetoder ...

## 4 Tunneleringsmetoder

I nedenstående tabeller er der angivet skematiske oversigter over hovedopgaver ved forskellige tunneleringsmetoder

### 4.1 Almindelige arbejdsoperationer

Almindelige arbejdsoperationer	AVN	EPB	Åben front	Åben front med trykluft
Tunneloperatør i maskinen		X	X	X
Almindelig adgang gennem tunnelen	X	X	X	X
Kontrolmålinger	X	X	X	X
Retningskontrol-landmåler	X	X	X	X
Arbejde under tryk	X	X		X
Regelmæssige inspektioner	X	X	X	X
Mindre reparationer	X	X	X	X
Passage af mellempresse stationer	X	X	X	X
Passage af Booster-pumpe	X			
Passage af jordvogn		X	X	X
Demontering af tunneludstyr	X	X	X	X
Injektion af overcut	X	X	X	X
Reparation af skader på rør	X	X	X	X

# Tunneleringsmetoder ...

## 4.2 Ergonomi i tunnel og TBM:

Manuelt arbejde	AVN	EPB	Åben front	Åben front med trykluft
Persontransport i tunnel	X	X	X	X
Udskiftning af skæreværktøjer i borehoved	X	X		
Vedligehold af grave-/ fræseværktøj			X	X
Transport igennem tunnel med værktøj og disk	X	X		
Fjernelse af forhindringer fra gravefront			X	X
Demontering af mellempresse stationer (Ø1600-Ø1800 ved længder over ca. 200m)	X	X	X	X
Demontering af booster pumper (Længder over ca. 500m)	X			
Reparation af skader i tunnel	X	X	X	X
Nedbrud og akut reparation af tunneleringsudstyr	X	X	X	X
Demontering af hydraulik pumpe	X	X	X	X
Rydning af tunnel	X	X	X	X
Injicering af overcut	X	X	X	X
Transport af forskellige emner til vedligehold	X	X	X	X
Rengøring af tunnel	X	X	X	X

# Tunneleringsmetoder ...

## 4.3 Beredskab og evakuering fra tunnel og TBM:

Uheld og ulykker	AVN	EPB	Åben front	Åben front med trykluft
Indskridning af jord ved gravefront			X	X
Indskridning af jord i borehoved	X	X		
Til skade kommende under arbejder under tryk i bore front	X	X		X
Ildebefindende i forbindelse med arbejde i tunnelen	X	X	X	X
Ildebefindende i forbindelse med alene arbejde på TBM (fx. Boreoperatør)		X	X	X
Passage af mellempresse stationer med bære	X	X	X	X
Passage af Booster-pumpe eller andre forhindringer i (), med bære	X	(X)	(X)	(X)
Passage af jordvogn med bære		X	X	X
Brand i tunnel	X	X	X	X
Brand på TBM	X	X	X	X

## Appendix 1 – Machine operations

### Machine operations

Working environment in AVN and EPB-machines

Martin Winther Vede

#### Contents

2	Machine operations AVN og EPB	18
2.1	Introduction	18
2.2	AVN Machine operations	3
2.3	EPB Machine operations	11
3	AVN Machine operations	19
4	EPB Machine operations	13

## 2 Machine operations AVN og EPB

### 2.1 Introduction

This appendix serves as a comprehensive guide to the operational procedures and safety protocols governing machine and tunnel activities associated with AVN and Earth Pressure Balance (EPB) tunneling methods. Given the complexity and inherent hazards of tunnel construction, particularly in mechanized tunneling environments, ensuring safety and regulatory compliance is paramount. The focus of this document is to provide detailed, step-by-step procedures addressing both machine operations and tunnel operations, with an emphasis on occupational health and safety management.

Throughout tunneling activities, a wide range of operational scenarios present unique risks that require vigilant oversight by contractors to ensure adherence to occupational health legislation and to safeguard the well-being of personnel. The document systematically outlines specific safety measures, emergency response protocols — such as fire incidents and personnel rescue — as well as practical guidelines for the transport of personnel and materials within confined tunnel environments.

Moreover, the document details the coordination of complex tasks such as the maintenance and replacement of drilling tools under compressed air, intermediate station repairs, dismantling operations, and the installation of critical equipment like slurry booster pumps and grouting systems. These components are essential for maintaining operational efficiency and structural integrity, while promoting a safe workplace.

Each section not only presents operational instructions but also integrates comprehensive safety checks, including ventilation and air quality verification, electrical and hydraulic system inspections, and the use of specialized safety equipment ranging from fresh air masks to emergency communication systems. The document also clarifies personnel requirements, rescue preparedness, and equipment handling protocols, reflecting best practices and compliance with relevant safety standards.

By consolidating these procedures and safety considerations into a singular, accessible reference, this document aims to support contractors, engineers, safety officers, and all involved personnel in the secure and effective execution of DN1600 AVN and EPB tunneling projects. Ultimately, this ensures both project success and the highest standards of occupational health and safety are maintained throughout all phases of tunnel construction.

# Appendix ...

## 3 AVN Machine operations

	Machine operations (AVN DN1600)		Tunnel operations (AVN DN1600)
1	Work in the tunnel/machine itself	1	Before Work in the tunnel/machine itself
2	Fire at the machine	2	Fire in the tunnel
3	Transport through the tunnel	3	Transport personnel through the tunnel
4	Rescue of personnel from the tunnel machine to terrain. Scenario heart attack.	4	Transport af loads in the tunnel
5	Compressed air, Replacement of drilling tools (Disc)	5	Work at intermediate stations repair/ dismantling
6	Slurry pump at the machine	6	Repair in the tunnel (Installation of a rubbering in the pipes, closing bentonite holes ex.
		7	Dismantling equipment in the tunnel. Pipes, cables, closing bentonite holes ex.
		8	Dæmmer/ grouting
		9	Installing Booster slurry pump

	Machine operations	Tunnel operations
1	<p><b>Before Work in the tunnel/machine itself</b></p> <p>When work of extended duration is to be performed inside the Tunnel Boring Machine (TBM), all tunnel equipment obstructing free access to the machine must be removed. This specifically includes the Booster slurry pump, which must be extracted from the tunnel to ensure adequate space and a safe working environment for personnel. For tasks of shorter duration, the Booster pump may remain in place; however, personnel will be required to navigate around or pass over it during their activities. In such cases, a safe and stable passage must be established over the Booster slurry pump to facilitate secure access for personnel and to minimize the risk of accidents. It should be noted that the Booster slurry pump is mounted on wheels, enabling it to be easily relocated. The pump can be pulled out of the tunnel using a wire winch, facilitating efficient removal without significant difficulty. If work is to be carried out inside the TBM of long duration, the Booster slurry pump must be removed from the tunnel. For small work durations, the Booster pump will stay, and personnel will need to pass it. (Booster pump is on wheels, and can be pulled out using a wire winch)</p> <p>Before any work in the machine startup, the following must be executed. Prior to commencing any work within the machine startup area, a series of preparatory procedures must be executed meticulously. These procedures are critical to establish a controlled and secure work environment while minimizing operational hazards during maintenance or inspection operations.</p> <p>Everyone who will be working in tunnel and TBM must have undergone a special safety introduction before the work can commence.</p> <p>Checklist prior to start work:</p> <ul style="list-style-type: none"> <li>• Site crane is ready for operations.</li> <li>• Site personnel is advised/instructed in the operations</li> <li>• The main power supply turns off</li> <li>• Air exchange and air quality ensured, Fresh air compressor checked             <ul style="list-style-type: none"> <li>– Backup fresh air compressor checked</li> <li>– Emergency generator checked</li> </ul> </li> <li>• Emergency light is installed in the tunnel and TBM as described in TUN 101 with a back-up orientation light lasting for at least 30 min.</li> <li>• Safety equipment checked             <ul style="list-style-type: none"> <li>– Stretcher</li> <li>– First aid equipment</li> <li>– Fresh air masks for a minimum of 20 minutes or longer if the tunnel length requires it.</li> <li>– Fire extinguisher</li> <li>– Gas detector</li> </ul> </li> </ul>	<p><b>Before Work in the tunnel</b></p> <p>If work of extended duration is to be carried out inside the tunnel, all tunnel equipment obstructing free access must be removed. For example it is mandatory to remove the Booster slurry pump from the tunnel to ensure unobstructed access and a safe working environment. In cases where the work duration is short, the Booster slurry pump may remain in place; however, personnel will be required to pass by or over the equipment during their tasks. In such instances, appropriate measures must be taken to establish a safe and stable passageway to facilitate secure and efficient movement of personnel around the pump. This precaution is essential to minimize potential risks and maintain operational safety within the confined tunnel space. If work is to be carried out inside the Tunnel of long duration, the Booster slurry pump must be removed from the tunnel. Small work durations, the Booster pump will stay, and personnel will need to pass it.</p> <p><b>Staff</b></p> <ul style="list-style-type: none"> <li>• Always minimum 2 people in the tunnel at a time</li> <li>• 1 Person in the shaft ready for rescue</li> <li>• 1 person on terrain ready for rescue</li> </ul> <p>Before any work in the tunnel startup, the following must be executed.</p> <ul style="list-style-type: none"> <li>• Site crane is ready for operations.</li> <li>• Site personnel is advised/instructed in the operations</li> <li>• The main power supply turns off</li> <li>• Air exchange and air quality ensured in the tunnel,             <ul style="list-style-type: none"> <li>– Fresh air compressor checked</li> <li>– Emergency generator checked</li> </ul> </li> <li>• Main light checked</li> <li>• Bring emergency lighting</li> <li>• Safety equipment checked             <ul style="list-style-type: none"> <li>– Stretcher</li> <li>– First aid equipment</li> <li>– Fresh air masks for a minimum of 20 minutes</li> <li>– Fire extinguisher</li> <li>– Gas detector</li> </ul> </li> <li>• Telephone landline is installed, Telephone at Shaft, all intermediate stations and the machine.</li> <li>• Trolley for transport of personnel and materials is checked.</li> <li>• Battery driven personnel transport is checked and used for entering the tunnel.</li> </ul>

# Appendix ...

Machine operations	Tunnel operations
<ul style="list-style-type: none"> <li>• Telephone line is installed fx. on WiFi, so personnel can come in contact with their colleges at all time.</li> <li>• Trolly for transport of personnel and materials is checked.</li> <li>• Battery driven personnel transport is checked and used for entering the tunnel.</li> <li>• Main power supply switched off before personnel enter the tunnel</li> <li>• Hydraulic stations are switched off before personnel enter the tunnel</li> <li>• In the tunnel at then TBM there will be installed censors/monitoring for the following               <ul style="list-style-type: none"> <li>– Oxygen level</li> <li>– CO2 level</li> <li>– Methane gas</li> <li>– LEL and VOC.</li> </ul> </li> <li>• Cameras is Checked before personnel enter the tunnel.</li> <li>• Tunnel lights               <ul style="list-style-type: none"> <li>– Stationary lighting in the tunnel run on separate light source.</li> </ul> </li> </ul>	
<p><b>2 Fire at the machine *</b></p> <p>There is little risk of fire and smoke in an AVN TBM. If a fire or heavy smoke breaks out, the tunnel is to be evacuated. The workforce at the TBM will:</p> <ul style="list-style-type: none"> <li>• Use the Fresh air masks.</li> <li>• Call out to the shaft and report the situation.</li> <li>• Evacuating the TBM and tunnel using Battery driven personnel transports</li> </ul> <p>Water curtains at the TBM It is recommended that water curtains be installed exclusively at the exit of the Tunnel Boring Machine (TBM) and further inside the tunnel to prevent direct contact between the water spray and components that may be involved in an oil fire. The primary function of these water curtains is to retard smoke development, thereby creating a safer environment that enables personnel to evacuate the tunnel promptly and reach safety. This precaution is especially important because if water curtains spray water directly onto burning oil, the fire risk may escalate, potentially intensifying the flames or causing hazardous spread. By strategically positioning water curtains in these locations, the risk of exacerbating an oil fire is minimized while still providing an effective smoke barrier. This approach enhances overall safety by mitigating smoke propagation without increasing the risk of fire escalation within the TBM and tunnel environmentIt is recommended that because there is a risk, that the workforce do not know what started the fire or smoke development, the use of water curtains cannot be allowed at the TBM. If it is an oil fire, the use of water curtains can escalate the situation.</p>	<p><b>Fire in the tunnel/tunnel equipment</b></p> <p>There is little risk of fire and smoke in the tunnel. The materiel/Equipment mounted in the tunnel is the following.</p> <ul style="list-style-type: none"> <li>• Main power cable Modules a water prof (For the TBM) (Electricity)</li> <li>• Secondar power cable Modules a water prof (For the lightning and placed power boxes in the tunnel) (Electricity)</li> <li>• Tunnel light (Electricity)</li> <li>• Pipes/hoses for fresh air (Air)</li> <li>• Pipe/hoses for the slurry line (Water, bentonite and underground materials)</li> <li>• Pipe/hoses for bentonite lubrication (Bentonite)</li> <li>• Bentonite modules placed ad the bentonite holes. Modules a water prof (Modules run on low voltage 230V)</li> <li>• Data cable for the TBM Modules a water prof (Cobber or fiber)</li> <li>• Data cable for the TBM navigation Modules is waterproof (Cobber or fiber)</li> <li>• Hose for the TBM navigation (Freezing fluids)</li> <li>• Landline for the telephone Modules is waterproof (Cobber or fiber)</li> <li>• Hydraulic hoses (Hydraulic)</li> <li>• Hydraulic cylinders (Intermediate Stations)</li> </ul> <p>As indicated in the list above, the system involves both hydraulic oil and electrical components. The coexistence of these two elements under optimal operating conditions presents a potential fire hazard. For ignition to occur, a specific sequence of events must take place involving the activation of multiple system components. Initially, the hydraulic pump becomes operational, pressurizing the hydraulic fluid. Should there be a breach in the hydraulic hose, such as a small rupture or perforation, pressurized hydraulic oil can be expelled at high velocity directly onto an exposed or compromised electrical component. In this scenario, the combination of flammable hydraulic oil and an electrical source capable of generating sparks or sufficient heat creates a risk of ignition. Consequently, the hydraulic oil may ignite, potentially resulting in a fire.</p> <p>Seen in the above list, there isHydraulic oil and there iselectricity. Combine the two in aperfectioncondition and there maybe a risk of fire. For a fire to start alle systems must be activated.</p> <p>The hydraulic pump is activatedand a small hole in the hydraulic hose spray oil directlyat a damagedelectric component. And now there is a chance for the oil to ignite. If the electrical system becomes exposed to water infiltration or experiences an ignition event, electrical current may short circuit, causing the protective relay system to activate and subsequently cut off the power supply, similar to the safety mechanisms employed in standard residential electrical installations.</p> <p>Once the power is interrupted, the hydraulic pump ceases operation, resulting in no pressure being exerted on the hydraulic hoses. Consequently, the absence of pressurized hydraulic fluid eliminates the presence of any potential combustible source within the hydraulic lines.</p> <p>Moreover, the deactivation of the electrical system removes the ignition source entirely, thereby significantly reducing the risk of fire or further damage. This</p>

\* There is no registered fire in an AVN micro tunneling machineever. However, should an AVN TBM ignite during operation. Then let it burn!!!. There are no people at the AVN machine when it is in operation or in the tunnel. In the tunnel itself there is nothing for igniting a fire, hydraulic oil is fed in dense pressurized hoses. Electrical cables and lighting are switched off at transition, i.e. the sheath of a cable, for example, is exposed. Relay turns off the power. If manning is required into the tunnel, the oil engine for hydraulic oil shall be switched off and the main power supply is turned off.

# Appendix ...

	Machine operations	Tunnel operations
		<p>automatic shutdown mechanism plays a critical role in maintaining overall system safety by isolating both the fuel and ignition components in the event of a fault. If an electric system take in water or ignites, the current will cross and the relay will cut off the power. Just like in a normal house. When the power is turned off, there will be no pressure on the hydraulic hoses and therefore no component/source to burn. Furthermore, when the power is turned off, the source for igniting is removed.</p>
3	<p><b>Transport personnel through the tunnel to the TBM *</b></p> <p>The conveyance of personnel through the tunnel to the Tunnel Boring Machine (TBM) is to be conducted exclusively by means of battery-powered personnel transport vehicles. In adherence to safety protocols, each personnel transport unit is designated for a single occupant at a time; additionally, at least two individuals must be present within each designated work zone in the tunnel to ensure safety and provide mutual assistance in the event of an emergency. Transport of personnel, is by using battery driven personnel transport. One person per transport and a minimum of 2 persons in the tunnel per work zone.</p> <p>All battery-powered personnel transport vehicles must be stationed in the shaft when not in active use. In circumstances where the tunnel is partially obstructed—such as by the presence of equipment like the slurry booster pump—it may be necessary to position an equivalent personnel transport vehicle on the opposite side of the obstruction. This ensures continuous accessibility and maintains the flexibility required for safe movement of personnel throughout the tunnel, irrespective of physical barriers. Battery driven personnel transports are placed in the shaft and at on the other side of the slurry booster pump in the tunnel. See drawing 01 must be placed in the shaft. If obstacles in the tunnel, it can be necessary to have a similar personnel transport on the other side of the obstacle. Ex slurry booster pump. Should personnel be required to undertake an inspection of the TBM and the tunnel, the following procedures must be executed: If personnel need to do inspection of the TBM and tunnel, the following will be performed: Personnel shall utilize battery-powered transport vehicles to facilitate safe and efficient travel within the tunnel environment. The personnel will use battery driven transports, to drive in the tunnel.</p> <ul style="list-style-type: none"> <li>• Personnel drive in the tunnel to the booster slurry pump. This pump is often installed 400-500m into the tunnel.</li> <li>• Personnel pass the booster slurry pump, by using the pathway that is placed on the side or top of the pump.</li> <li>• There are placed 2 Battery driven transports on the other side of the booster slurry pump. Personnel use this to drive to the TBM.</li> <li>• At the booster slurry pump, the charging-station is placed for the transports. Because the charging is at the booster slurry pump, there will never be personnel in the tunnel, when the transports is charging.</li> </ul>	<p><b>Transport personnel through the tunnel</b></p> <p>Transport of personnel is by using a battery/battery driven personnel transport. One person/One-person per transport and a minimum of 2 persons/people in the tunnel per work zone.</p> <p>There are placed personnel transport/transport in the shaft and transport/transport on the other side of the slurry booster pump in the tunnel. <i>See drawing 01</i></p> <p>If personnel need to do inspection of the TBM and tunnel, the following will be performed.</p> <p>The personnel will use Battery driven transports, to drive in the tunnel.</p> <ul style="list-style-type: none"> <li>• Personnel drive in the tunnel to the booster slurry pump, this pump is often installed 400-500m in the tunnel.</li> <li>• Personnel pass the booster slurry pump, by using the pathway that is placed on the side of the pump.</li> <li>• There is placed 2 Battery driven transports on the other side of the booster slurry pump. Personnel will use this to drive to the TBM.</li> <li>• At the booster slurry pump, the charging-station is placed for the transports. Because the charging is at the booster slurry pump, there will never be personnel in the tunnel, when the transports is charging.</li> </ul>
4	<p><b>Rescue of personnel from the tunnel machine to terrain. Scenario: fainted personnel. TBM AVN</b></p> <p>Scenario: 2 people work at the TBM, one person faints and has to be brought to terrain.</p> <ul style="list-style-type: none"> <li>• The personnel at the TBM contact/contact the personnel in the shaft, by using the installed telephone landline. The personnel in the shaft call emergency 112.</li> <li>• At the TBM the injured personnel is placed on a stretcher (by 2 persons) that is on a trolley and is pushed to the Booster Slurry Pump.</li> <li>• The personnel in the shaft prepares the trolley, that is placed in the shaft with the first aid kit.</li> <li>• 2 persons from the shaft enter the tunnel with the trolley, and go to the booster slurry pump.</li> <li>• At the Slurry booster pump, the injured personnel is lifted up by using a chain hoist and slides over the pump.</li> <li>• The injured personnel is now placed on the trolley from the shaft.</li> <li>• One person push/pushes the trolley to the shaft and the remaining 2 persons, drive out by using the 2 Battery driven personnel transport, the is placed at the slurry booster pump.</li> <li>• In the shaft, the injured personnel is lifted up/lifted to terrain, by using the site crane. The stretcher is build for lifting.</li> </ul>	<p><b>Transport of loads in the tunnel</b></p> <p><b>Transport from shaft to the Booster slurry pump</b></p> <ul style="list-style-type: none"> <li>• Cutting tools are placed in boxes and transported on a trolley pulled by a wire/hydraulic motor/hydraulic motor to the booster slurry pump</li> <li>• The boxes and trolley are lifted up/lifted by using a chain hoist and slides over the pump.</li> <li>• The boxes and trolley are put down</li> <li>• Personnel use the passage on the side of the pump</li> </ul> <p><b>Transport from the Booster slurry pump to the TBM</b></p> <p>Passing the slurry pump at the TBM (Personnel and Loads/materials).</p> <ul style="list-style-type: none"> <li>• The Box and trolley is pulled by a wire to the TBM</li> <li>• The Box is lifted up, by using a chain hoist and slides over the pump on the trolley line.</li> <li>• When the Box has passed the slurry pump, the load can be placed in the TBM for further handling.</li> <li>• Personnel use the passage on the side of the pump</li> </ul>

\* DWA-A 125

	Machine operations	Tunnel operations
5	<p><b>Compressed air. Compressed Air and Replacement of Disc Drilling Tools</b>  <b>Replacement by disk drilling tool</b></p> <p>Prior to the commencement of tunnelling operations, cutting tools are pre-positioned at the Tunnel Boring Machine (TBM) to minimize the need for subsequent lifting and manual handling, thereby enhancing both efficiency and safety. This preparatory measure is designed to reduce the risk of injury and streamline the replacement process. In circumstances where it becomes necessary to transport cutting tools from the shaft to the TBM, the following procedural steps must be observed: Before the actual tunnelling starts, cutting tools are laid at the machine, this is to reduce lifting and handling. If cutting tools are to be transported from the shaft and to the TBM there are following steps:</p> <p><b>Transport from shaft to the Booster slurry pump</b></p> <ul style="list-style-type: none"> <li>• Cutting tools are placed in boxes and transported on a trolley pushed by personnel through the tunnel, and to the slurry booster pump.</li> <li>• The boxes are sifted up, by using a chain hoist and slides over the pump.</li> <li>• The boxes are put down on the trolley, that is placed on this side of the pump.</li> <li>• Personnel use the passage on the side of the pump</li> <li>• The trolley is pushed to the TBM.</li> </ul> <p><b>Transport from the Booster slurry pump to the TBM</b></p> <p>Passing the slurry pump at the TBM (Personnel and Loads/materials).</p> <ul style="list-style-type: none"> <li>• The cutting tools on the trolley are placed next to the slurry pump.</li> <li>• The Cutting tools are lifted up, by using a chain hoist and slides over the pump on the trolley line.</li> <li>• When the Cutting tools has passed the slurry pump, the load can be placed in the TBM for further handling.</li> <li>• Personnel use the passage on the side of the pump</li> </ul> <p><b>Work with compressed Air</b></p> <p>When the cutting tools need to be changed, the work is performed under compressed air. Before work with compressed air can start, personnel need to be medical approved, and approved and trained in the equipment and procedures. Furthermore, the TBM needs to be equipped with a certain safety installation.</p> <ul style="list-style-type: none"> <li>• All personnel are dive approved (Medical approved)</li> <li>• All personnel are trained in the airlock systems.</li> <li>• The machine is installed with emergency locks, so that personnel that is working under compressed air, can get help. <ul style="list-style-type: none"> <li>– Fresh air compressor</li> </ul> </li> <li>• Air is pumped up in the air tank that acts as a main and backup tank., if the pressure drops in this tank, the emergency compressor is automatically turned on.</li> <li>• Emergency fresh air compressor</li> <li>• Emergency generator <ul style="list-style-type: none"> <li>– All systems are designed to initiate automatically. In the event that the compressors do not receive electrical power, the emergency generator will be activated to supply the necessary voltage and ensure uninterrupted operation of the compressors and associated systems. All systems are started automatically, if there is no voltage at the compressors and the emergency generator starts.</li> </ul> </li> <li>• At a minimum, two individuals must be present within the pressure chamber to conduct the work. In addition, one designated operator is responsible for monitoring and controlling the pressure system at the Tunnel Boring Machine (TBM). Furthermore, a dedicated rescue team must be in place: one person positioned at the TBM, ready to initiate rescue operations if necessary; one individual stationed at the base of the shaft (in the pit), prepared to assist in rescue situations; and one person located on the surface (terrain), also prepared for immediate intervention. This arrangement brings the minimum total number of required personnel to six, thereby ensuring that both operational and emergency protocols can be implemented without delay in the event of an incident. When working under compressed air, the minimum personnel is 2 in the pressure chamber, and 1 person controls the pressure system at the TBM, 1 person is ready for rescue at the machine. 1 person stands in the pit ready for rescue. 1 person stands on terrain ready for rescue. In total 6 persons.</li> <li>• When replacing cutting tools, chains and lifting equipment are used, so that the crew does not lift them directly.</li> </ul>	<p><b>Work at intermediate stations repair/ dismantling</b></p> <p>A variety of operations can be performed at the intermediate station, with the primary activities encompassing the repair and dismantling of hydraulic jacks located within the station. When working at the intermediate station a lot of different operations can be performed. Main categories are repair and dismantling of hydraulic jacks in the station.</p> <p><b>Repair</b></p> <p>When repairs are conducted at the intermediate stations, the main electrical power supply is disconnected, and hydraulic pressure to the station is simultaneously relieved. This safety protocol effectively eliminates the risk of fire ignition within the tunnel equipment during maintenance activities. In cases where the repair work involves hot work operations, such as the use of angle grinders or blowtorches, personnel are required to comply with Danish safety regulations. Specifically, they must possess a valid certification for performing hot work and adhere to the European CFFA Guideline No. 12, which outlines best practices and safety measures for fire prevention during such tasks. If repair is performed in the stations, the main electric power is turned off, and the hydraulic pressure to the intermediate station is cut off. Now there is no risk of starting a fire on the tunnel equipment.</p> <p>If the work includes hot work, ex. Angel grinder or a blowtorch, the personnel need to follow the Danish instruction and have a valid Course certificate for this and it must follow the European CFFA Guideline nr. 12..</p> <ul style="list-style-type: none"> <li>• The Personnel use the trolley that is placed in the shaft for materials. One person pushes the trolley and the colleague use the electric transport to the work Zone</li> <li>• When the personnel are at the work zone, they either work on their knees, if the work is close to the bottom of the tunnel, or they sit on the trolley if the work is placed higher.</li> </ul> <p><b>Dismantling off the intermediate stations</b></p> <p>The dismantling process of the intermediate station commences once the Tunnel Boring Machine (TBM) has arrived at and been removed from the end shaft. Additionally, the slurry booster pumps are extracted from the tunnel. Under these conditions, the tunnel attains unrestricted airflow, with no physical obstructions impeding movement, and two available exits providing safe egress routes. To facilitate the removal of equipment such as trolleys during dismantling, hydraulic winches may be installed at both the start and end shafts. These winches enable controlled pulling of the trolley in both directions, ensuring efficient and safe handling of heavy components within the tunnel environment. When the intermediate station is to be dismantled, the TBM have arrived and removed from the end shaft. The slurry booster pumps will also be removed from the tunnel. Now there is free airflow in the tunnel, no obstacles and there are two exits. (A hydraulic winch can be installed in the start, and end shaft to pull the trolley in both directions.</p> <ul style="list-style-type: none"> <li>• The personnel remove cylinders from the bottom and sides first, by lifting them with a chain hoist. This chain hoist is fixed to the cylinder in the top. This work is performed from the knees.</li> <li>• When the cylinders are removed from the bottom and sides and placed on the trolley, the trolley is pushed out to the shaft and emptied.</li> <li>• The trolley is now loaded with pallets, so the pallets height, is about 30cm from top pipe (ID)</li> <li>• The trolley is now pushed in under the intermediate station cylinders, and the top cylinders are dismantled, and falls 30 cm down on the pallet, this work can be performed by personnel sitting on a chair.</li> <li>• When all of the cylinders are removed, the intermediate station is pushed together, with the main jacking cylinders in the shaft.</li> </ul>

# Appendix ...

	Machine operations	Tunnel operations
6		<p><b>Repair in the tunnel (Installation of a rubbering in the pipes, closing bentonite holes ex.</b></p> <p>The Tunnel Boring Machine (TBM) has successfully arrived at and been removed from the end shaft, and the slurry booster pumps and other equipment have likewise been extracted from the tunnel. As a result, unobstructed airflow is now established within the tunnel, with all obstacles cleared and two accessible exits available.</p> <p>To facilitate the movement of trolleys during subsequent operations, hydraulic winches have been installed at both the start and end shafts. These winches allow for controlled and safe towing of the trolley in both directions, thereby enhancing operational efficiency and safety within the tunnel environment.</p> <p>TBM have arrived and removed from the end shaft and the slurry pumps are removed from the tunnel. Now there is free airflow in the tunnel, no obstacles and there are two exits.</p> <p>A hydraulic winch is installed in the start, and end shaft to pull the trolley in both directions. The work positions will be the same in all work scenarios.</p> <ul style="list-style-type: none"> <li>• Personnel drive to the work zone, using the electric transports.</li> <li>• The trolley is pulled in loaded with tools and materials, for the work assignment</li> <li>• Personnel will work either on their knees or sitting on the trolley.</li> </ul>
7		<p><b>Dismantling equipment in the tunnel. Pipes, cables, closing bentonite holes ex.</b></p> <p>The Tunnel Boring Machine (TBM) has successfully arrived at and been removed from the end shaft, and the slurry booster pumps and other equipment have likewise been extracted from the tunnel. As a result, unobstructed airflow is now established within the tunnel, with all obstacles cleared and two accessible exits available.</p> <p>To facilitate the movement of trolleys during subsequent operations, hydraulic winches have been installed at both the start and end shafts. These winches allow for controlled and safe towing of the trolley in both directions, thereby enhancing operational efficiency and safety within the tunnel environment. TBM have arrived and removed from the end shaft and the 2 slurry pumps are removed from the tunnel. Now there is free airflow in the tunnel, no obstacles and there are two exits.</p> <p>A hydraulic winch is installed in the start, and end shaft to pull the trolley in both directions.</p> <ul style="list-style-type: none"> <li>• Personnel drive to the work zone, using the electric transports.</li> <li>• The trolley is placed next to ex. hose that need to be dismantled, a person is standing on each side of the trolley</li> <li>• The personnel now lift the hose down from the rack and on the trolley.</li> <li>• When the trolley is loaded, personnel use the telephone installed at the intermedia station, to call personnel placed in the shaft. The load is pulled out to the shaft.</li> <li>• When the personnel need to dismantle heavy equipment like electric cables, the cables are taken down 3-5 meters at a time and put on the trolley. At this way, the workers are lifting a minimum.</li> </ul> <p>When the equipment is getting to heavy to lift by hand, the personnel will use either a chain hoist mounted at the top of the tunnel pipe.</p> <p>It is also possible of using a customized, electric crane mounted on the undercarriage of the trolley.</p>
8		<p><b>Dämmer/ grouting</b></p> <p>Upon completion of the tunneling process, the majority of the equipment within the tunnel is removed. One critical step in the finalization phase involves stabilizing the overcut surrounding the tunnel pipe. This stabilization is achieved by injecting grout material, specifically dämmer, into the overcut through bentonite injection nozzles. Bentonite pipes are installed throughout the tunnel at regular intervals, typically with every third pipe designated as a bentonite pipe. Each bentonite pipe is equipped with approximately three bentonite nozzles positioned along the circumference of the pipe to ensure even distribution of grout. The standard locations of these nozzles within the pipe are at approximately the 2 o'clock, 5 o'clock, and 7 o'clock positions.</p> <p>This systematic injection of dämmer through the bentonite nozzles plays a vital role in reinforcing the soil around the tunnel lining, thereby enhancing the structural stability and long-term integrity of the tunnel.</p> <p>When tunneling is finished, most of the equipment inside the tunnel is removed, and the overcut around the tunnel pipe must be stabilized. This is done by injecting dämmer into the overcut via the bentonite nozzles. Every third pipe in the tunnel stretch is a bentonite pipe, and each bentonite pipe has typically 3 bentonite nozzles. (Location of the nozzles in the pipe is kl.2...kl.5...kl.7.</p>

# Appendix ...

	Machine operations	Tunnel operations
		<ul style="list-style-type: none"> <li>• The work processes, processes for this work assignment can be performed by this following steps.</li> <li>• The automatic bentonite system is dismantled, leaving only bentonite nozzles.</li> <li>• Personnel in the tunnel connect a 1 inch rubber hose to the bentonite nozzle. This hose is connected with relates to the main bentonite line, which was previously used.</li> <li>• The tunnel staff contact the staff who mix and control the pumping of Ddämmer. Pumping is initiated.</li> <li>• The staff in the tunnel make sure the overcut is filled with dDämmer when the external pressure in the overcutter is sufficient. This is done visually via a pressure gauge, which is mounted on the 1 inch hose</li> <li>• When the overcut is filled, the 1 inch hose is removed and mounted on the next bentonite nozzle and work processes are started again.</li> <li>• When the entire tunnel section overcut is sufficiently filled, the remaining pipes are dismantled. See Dismantling equipment in the tunnel. Pipes, cables, closing bentonite holes ex.</li> </ul>
9		<p><b>Installing Booster slurry pump</b></p> <p>A slurry booster pump must be installed typically after the 400-500 meter tunnel is performed. This pump help maintain the pump pressure, so that the slurry materials can be pumped.</p> <p>The pump is installed from the pit and into the first tunnel pipe.</p> <ul style="list-style-type: none"> <li>• The pump is hoisted into the pit with the construction site crane.</li> <li>• The pump is pushed into the first tunnel pipe</li> <li>• Personnel connect the pump inside the tunnel approximately 2 to 3 meters inside.</li> </ul> <p>To connect the pump, one power cable and 2 Pcs 4-6 inch hoses is connected.</p>

# Appendix ...

## 4 EPB Machine operations

Machine operations (EPB DN1600)		Tunnel operations (EPB DN1600)	
1	Work in the tunnel/machine itself	1	Before Work in the tunnel/machine itself
2	Fire at the machine	2	Fire in the tunnel
3	Transport through the tunnel	3	Transport personnel through the tunnel
4	Rescue of personnel from the tunnel machine to terrain. Scenario heart attack.	4	Transport af loads in the tunnel
5	Compressed air, Replacement of drilling tools (Disc)	5	Work at intermediate stations repair/ dismantling
6	Soil cart at the machine	6	Repair in the tunnel (Installation of a rubbering in the pipes, closing bentonite holes ex.
		7	Dismantling equipment in the tunnel. Pipes, cables, closing bentonite holes ex.
		8	Dæmmer/ grouting

Machine operations		Tunnel operations	
1	<p><b>Before Work in the tunnel/machine itself</b></p> <p>When work of extended duration is to be performed inside the Tunnel Boring Machine (TBM), all tunnel equipment obstructing free access to the machine must be removed. This specifically includes the soil cart, which is used to transport soil from the tunnel boring machine to the pit. This must be extracted from the tunnel to ensure adequate space and a safe working environment for personnel. For tasks of shorter duration, this also applies</p> <p>Prior to commencing any work within the machine startup area, a series of preparatory procedures must be executed meticulously. These procedures are critical to establish a controlled and secure work environment while minimizing operational hazards during maintenance or inspection operations. Everyone who will be working in tunnel and TBM must have a special safety introduction before the work can commence.</p> <p>Checklist prior to start work:</p> <ul style="list-style-type: none"> <li>• Site crane is ready for operations.</li> <li>• Site personnel is advised/instructed in the operations</li> <li>• The main power supply turns off</li> <li>• Air exchange and air quality ensured, Fresh air compressor checked <ul style="list-style-type: none"> <li>– Backup fresh air compressor checked</li> <li>– Emergency generator checked</li> </ul> </li> <li>• Emergency light is installed in the tunnel and TBM with a back-up orientation light lasting for at least 30 min.</li> <li>• Safety equipment checked <ul style="list-style-type: none"> <li>– Stretcher</li> <li>– First aid equipment</li> <li>– Fresh air masks for a minimum of 20 minutes</li> <li>– Fire extinguisher</li> <li>– Gas detector</li> </ul> </li> <li>• Telephone line is installed fx. on WiFi, so personnel can come in contact with their colleges at all time.</li> <li>• Trolley for transport of personnel and materials is checked.</li> <li>• Battery driven personnel transport is checked and used for entering the tunnel.</li> <li>• Hydraulic stations are switched off before personnel enter the tunnel</li> <li>• In the tunnel at the TBM there will be installed sensors/monitoring for the following <ul style="list-style-type: none"> <li>– Oxygen level</li> <li>– CO2 level</li> <li>– Methane gas</li> <li>– LEL and VOC.</li> </ul> </li> <li>• Cameras is Checked before personnel enter the tunnel.</li> <li>• Tunnel lights <ul style="list-style-type: none"> <li>– Stationary lighting in the tunnel run on separate light source.</li> </ul> </li> </ul>		<p><b>Before Work in the tunnel</b></p> <p>If work of extended duration is to be carried out inside the tunnel, all tunnel equipment obstructing free access must be removed. For example it is mandatory to remove the soil cart from the tunnel to ensure unobstructed access and a safe working environment. For tasks of shorter duration, this also applies. This precaution is essential to minimize potential risks and maintain operational safety within the confined tunnel space.</p> <p><b>Staff</b></p> <ul style="list-style-type: none"> <li>• Always minimum 2 people in the tunnel at a time</li> <li>• 1 Person in the shaft ready for rescue</li> <li>• 1 person on terrain ready for rescue</li> </ul> <p>Before any work in the tunnel startup, the following must be executed.</p> <ul style="list-style-type: none"> <li>• Site crane is ready for operations.</li> <li>• Site personnel is advised/instructed in the operations</li> <li>• The main power supply turns off</li> <li>• Air exchange and air quality ensured in the tunnel, <ul style="list-style-type: none"> <li>– Fresh air compressor checked</li> <li>– Emergency generator checked</li> </ul> </li> <li>• Main light checked</li> <li>• Bring emergency lighting</li> <li>• Safety equipment checked <ul style="list-style-type: none"> <li>– Stretcher</li> <li>– First aid equipment</li> <li>– Fresh air masks for a minimum of 20 minutes</li> <li>– Fire extinguisher</li> <li>– Gas detector</li> </ul> </li> <li>• Telephone landline is installed, Telephone at Shaft, all intermediate stations and the machine.</li> <li>• Trolley for transport of personnel and materials is checked.</li> <li>• Battery driven personnel transport is checked and used for entering the tunnel.</li> </ul>

# Appendix ...

	Machine operations	Tunnel operations
2	<p><b>Fire at the machine *</b></p> <p>There is little risk of fire and smoke in an TBM. If a fire or heavy smoke breaks out, the tunnel is to be evacuated. The workforce at the TBM will:</p> <ul style="list-style-type: none"> <li>• Use the Fresh air masks.</li> <li>• Call out to the shaft and report the situation.</li> <li>• Evacuating the TBM and tunnel using Battery driven personnel transports</li> </ul> <p>Water curtains at the TBM It is recommended that water curtains be installed exclusively at the exit of the Tunnel Boring Machine (TBM) and further inside the tunnel to prevent direct contact between the water spray and components that may be involved in an oil fire. The primary function of these water curtains is to retard smoke development, thereby creating a safer environment that enables personnel to evacuate the tunnel promptly and reach safety. This precaution is especially important because if water curtains spray water directly onto burning oil, the fire risk may escalate, potentially intensifying the flames or causing hazardous spread. By strategically positioning water curtains in these locations, the risk of exacerbating an oil fire is minimized while still providing an effective smoke barrier. This approach enhances overall safety by mitigating smoke propagation without increasing the risk of fire escalation within the TBM and tunnel environment</p>	<p><b>Fire in the tunnel/tunnel equipment</b></p> <p>There is little risk of fire and smoke in the tunnel. The materiel/Equipment mounted in the tunnel is the following.</p> <ul style="list-style-type: none"> <li>• Main power cable Modules a water prof (For the TBM) (Electricity)</li> <li>• Secondar power cable Modules a water prof (For the lightning and placed power boxes in the tunnel) (Electricity)</li> <li>• Tunnel light (Electricity)</li> <li>• Pipes/hoses for fresh air (Air)</li> <li>• Pipe/hoses for the slurry line (Water, bentonite and underground materials)</li> <li>• Pipe/hoses for bentonite lubrication (Bentonite)</li> <li>• Bentonite modules placed ad the bentonite holes. Modules a water prof (Modules run on low voltage 230V)</li> <li>• Data cable for the TBM Modules a water prof (Cobber or fiber)</li> <li>• Data cable for the TBM navigation Modules is waterproof (Cobber or fiber)</li> <li>• Hose for the TBM navigation (Freezing fluids)</li> <li>• Landline for the telephone Modules is waterproof (Cobber of fiber)</li> <li>• Hydraulic hoses (Hydraulic)</li> <li>• Hydraulic cylinders (Intermediate Stations)</li> </ul> <p>As indicated in the list above, the system involves both hydraulic oil and electrical components. The coexistence of these two elements under optimal operating conditions presents a potential fire hazard. For ignition to occur, a specific sequence of events must take place involving the activation of multiple system components. Initially, the hydraulic pump becomes operational, pressurizing the hydraulic fluid. Should there be a breach in the hydraulic hose, such as a small rupture or perforation, pressurized hydraulic oil can be expelled at high velocity directly onto an exposed or compromised electrical component. In this scenario, the combination of flammable hydraulic oil and an electrical source capable of generating sparks or sufficient heat creates a risk of ignition. Consequently, the hydraulic oil may ignite, potentially resulting in a fire.</p> <p>If the electrical system becomes exposed to water infiltration or experiences an ignition event, electrical current may short circuit, causing the protective relay system to activate and subsequently cut off the power supply, similar to the safety mechanisms employed in standard residential electrical installations.</p> <p>Once the power is interrupted, the hydraulic pump ceases operation, resulting in no pressure being exerted on the hydraulic hoses. Consequently, the absence of pressurized hydraulic fluid eliminates the presence of any potential combustible source within the hydraulic lines.</p> <p>Moreover, the deactivation of the electrical system removes the ignition source entirely, thereby significantly reducing the risk of fire or further damage. This automatic shutdown mechanism plays a critical role in maintaining overall system safety by isolating both the fuel and ignition components in the event of a fault.</p>
3	<p><b>Transport personnel through the tunnel to the TBM **</b></p> <p>The conveyance of personnel through the tunnel to the Tunnel Boring Machine (TBM) is to be conducted exclusively by means of battery-powered personnel transport vehicles. In adherence to safety protocols, each personnel transport unit is designated for a single occupant at a time; additionally, at least two individuals must be present within each designated work zone in the tunnel to ensure safety and provide mutual assistance in the event of an emergency.</p> <p>All battery-powered personnel transport vehicles must be stationed in the shaft, when there is no personnel in the tunnel boring machine or in the tunnel. When the tunnel boring machine is in operation, here will also be a means of transport inside the tunnel boring machine, that the drill operator can use.</p> <p>In circumstances where the tunnel is partially obstructed—such as by the presence of equipment like the soil cart, Should personnel be required to undertake an inspection of the TBM and the tunnel because the tow wire is broken on the soil cart, the following procedures must be executed:</p>	<p><b>Transport personnel through the tunnel</b></p> <p>Transport of personnel is by using battery driven personnel transport. One-person pr transport and a minimum of 2 people in the tunnel pr work zone. There are placed personnel transport in the tunnel boring machine (if not remotely controlled) and in the pit. If personnel need to do inspection of the TBM and tunnel, the following will be performed. The personnel will use Battery driven transports, to drive in the tunnel.</p> <ul style="list-style-type: none"> <li>• Personnel must maintain communication with the machine operator and ensure that the soil cart is either driven out to the pit and only brought back in, after all personnel have left the tunnel, or that the soil cart remains securely positioned at the tunnel boring machine</li> <li>• Personnel drive in the tunnel to for their work tasks</li> <li>• If the soil cart is at the tunnel boring machine, the personnel will pass it by placing plates on top of the soil cart, and the personal pass over</li> </ul>

\* There is no registered fire in an micro tunneling machine. However, should an TBM ignite during operation. Ensure that all personnel are out of the tunnel boring machine and the tunnel itself. Do not attempt to extinguish the fire. Let it burn. In the tunnel itself there is nothing for igniting a fire, hydraulic oil is fed in dense pressurized hoses. Electrical cables and lighting are switched off at transition, i.e. the sheath of a cable, for example, is exposed. Relay turns off the power. If manning is required into the tunnel, the oil engine for hydraulic oil shall be switched off and the main power supply is turned off.

\*\* DWA-A 125

# Appendix ...

Machine operations	Tunnel operations
<p>Personnel shall utilize battery-powered transport vehicles to facilitate safe and efficient travel within the tunnel environment.</p> <ul style="list-style-type: none"> <li>Personnel drive in the tunnel to the soil cart. This soil cart may risk stopping in case of a breakdown along the entire tunnel section.</li> <li>Personnel can pass the soil cart, by laying plates over the soil cart if needed.</li> <li>The Battery driven transports is lifted over the soil cart if necessary.</li> <li>If the EPB is not remotely controlled, personnel from the tunnel boring machine can access the soil cart from the opposite side to assist with repairs, ensuring staff are positioned on both sides and eliminating the need to climb over the soil cart.</li> </ul>	
<p><b>4</b> <b>Rescue of personnel from the tunnel machine to terrain.</b>  <b>TBM EPB</b>  <b>Scenario 2</b> occurs during the work process when a loaded soil cart is pulled out to the shaft for unloading. On its way through the tunnel, the wheel on the soil cart is damaged to such an extent that the cart comes to a stop and cannot be pulled out by the wire. Personnel from the TBM and the shaft drive to the damaged soil cart to inspect the damage. The person positioned between the TBM and the soil cart slips, hits their head, and loses consciousness. The accident happens when the person dismounts the electric transport vehicle near the soil cart</p> <ul style="list-style-type: none"> <li>Personnel in the shaft pull the soil cart out to the shaft, but the soil cart stops inside the tunnel.</li> <li>Personnel in the shaft contact the drill operator and inform them about the situation.</li> <li>Two people from the shaft call personnel on the surface, ensuring there is always staff in the shaft. Personnel from the shaft drive to the soil cart, and the drill operator also drives to the soil cart.</li> <li>The drill operator dismounts the battery-powered transport vehicle, falls, hits their head, and loses consciousness.</li> <li>Personnel now at the damaged soil cart, between the soil cart and the shaft, see their colleague lying in the tunnel pipe on the opposite side of the soil cart.</li> <li>Personnel in the tunnel by the soil cart call the personnel in the shaft to inform them about the situation.</li> <li>Personnel in the shaft call 112 (emergency) and bring a rescue stretcher and first aid kit into the tunnel to the soil cart.</li> <li>Personnel already in the tunnel, between the soil cart and the shaft, immediately begin the rescue operation. Personnel use the two installed rescue planks found on the sides of the soil cart.</li> <li>The rescue planks are placed on top of the soil cart so that they span from the front to the back of the soil cart. The rescue planks are equipped with lifting handles, which personnel use to handle them, and end stops that lock the planks onto the soil cart. (The planks are handled by one person.) <ul style="list-style-type: none"> <li>The rescue planks are lifted 20 mm at one end, over the shelf stop, and pulled out of the shelf.</li> <li>When a rescue plank is pulled out, one end is lifted onto the cart with the end stop facing up. Then the opposite end of the rescue plank is lifted and pushed over the soil cart.</li> </ul> </li> </ul> <p>When the rescue plank is placed on the soil cart, it is turned so the end stop faces down toward the soil cart and locks the ends in place. Two people climb over the soil cart and place the injured person on the brought-in rescue stretcher. The injured person is strapped onto the stretcher.</p> <p>There are now five people in the tunnel: one injured person, two people between the TBM and the soil cart, and two people between the soil cart and the shaft.</p> <ul style="list-style-type: none"> <li>The rescue stretcher is lifted onto the rescue planks, first lifting one end so the front of the stretcher rests on the rescue planks. Then the back end of the stretcher is lifted onto the rescue planks. (Lifting the stretcher should be done in stages to minimize the burden on the rescuers.)</li> <li>The injured person is pulled/pushed over the rescue planks by personnel on each side of the soil cart.</li> <li>Personnel between the soil cart and the shaft receive the injured person and transport them to the shaft. Four wheels are mounted on the rescue stretcher, and the stretcher is pulled out to the shaft.</li> </ul>	<p><b>Transport of loads in the tunnel</b>  <b>Transport from shaft to the tunnel/machine</b></p> <p>The soil cart must be removed from the tunnel to ensure clear passage between the pit and the tunnel boring machine</p> <ul style="list-style-type: none"> <li>Cutting tools are placed in boxes and transported on a trolley pulled by a wire/hydraulic motor to the tunnel boring machine.</li> <li>When the equipment is at the tunnel boring machine, the equipment is lifted by using a chain hoist which is connected to an overhead beam. This beam is installed along the length of the tunnel boring machine</li> </ul>

# Appendix ...

	Machine operations	Tunnel operations
5	<p><b>Compressed Air and Replacement of Disc Drilling Tools</b> Prior to the commencement of tunnelling operations, cutting tools are pre-positioned at the Tunnel Boring Machine (TBM) to minimize the need for subsequent lifting and manual handling, thereby enhancing both efficiency and safety. This preparatory measure is designed to reduce the risk of injury and streamline the replacement process. In circumstances where it becomes necessary to transport cutting tools from the shaft to the TBM, the following procedural steps must be observed:</p> <p><b>Transport from shaft to the tunnel boring machine</b></p> <ul style="list-style-type: none"> <li>• The soil cart is pulled out to the pit by a wire.</li> <li>• Cutting tools placed in boxes and transported on a trolley pulled by wire through the tunnel, and to the tunnel boring machine.</li> <li>• The boxes are lifted up, by using a chain hoist which is connected to an overhead beam. This beam is installed along the length of the tunnel boring machine</li> <li>• When the cases are at the pressure chambers, the cases are opened and the cutter disc is lifted with chain hoists attached inside the pressure chambers on the ceiling.”</li> </ul> <p><b>Work with compressed Air</b> When the cutting tools need to be changed, the work is performed under compressed air. Before work with compressed air can start, personnel need to be medical approved and trained in the equipment and procedures. Furthermore, the TBM needs to be equipped with a certain safety installation.</p> <ul style="list-style-type: none"> <li>• All personnel are dive approved (Medical approved)</li> <li>• All personnel are trained in the airlock systems.</li> <li>• The machine is installed with emergency locks, so that personnel that is working under compressed air, can get help.</li> <li>• Fresh air compressor</li> <li>• Air is pumped up in the air tank that acts as a main and backup tank. If the pressure drops in this tank, the emergency compressor is automatically turned on.</li> <li>• Emergency fresh air compressor</li> <li>• Emergency generator <ul style="list-style-type: none"> <li>– All systems are designed to initiate automatically. In the event that the compressors do not receive electrical power, the emergency generator will be activated to supply the necessary voltage and ensure uninterrupted operation of the compressors and associated systems.</li> </ul> </li> <li>• At a minimum, two individuals must be present within the pressure chamber to conduct the work. In addition, one designated operator is responsible for monitoring and controlling the pressure system at the Tunnel Boring Machine (TBM). Furthermore, a dedicated rescue team must be in place: one person positioned at the TBM, ready to initiate rescue operations if necessary; one individual stationed at the base of the shaft (in the pit), prepared to assist in rescue situations; and one person located on the surface (terrain), also prepared for immediate intervention. This arrangement brings the minimum total number of required personnel to six, thereby ensuring that both operational and emergency protocols can be implemented without delay in the event of an incident.</li> <li>• When replacing cutting tools, chains and lifting equipment are used, so that the crew does not lift them directly.</li> </ul>	<p><b>Work at intermediate stations repair/ dismantling</b> A variety of operations can be performed at the intermediate station, with the primary activities encompassing the repair and dismantling of hydraulic jacks located within the station</p> <p><b>Repair</b> When repairs are conducted at the intermediate stations, the main electrical power supply is disconnected, and hydraulic pressure to the station is simultaneously relieved. This safety protocol effectively eliminates the risk of fire ignition within the tunnel equipment during maintenance activities. In cases where the repair work involves hot work operations, such as the use of angle grinders or blowtorches, personnel are required to comply with Danish safety regulations. Specifically, they must possess a valid certification for performing hot work and adhere to the European CFPD Guideline No. 12, which outlines best practices and safety measures for fire prevention during such tasks.</p> <ul style="list-style-type: none"> <li>• the soil cart are extracted from the tunnel</li> <li>• The Personnel use the trolley that is placed in the shaft for materials. The trolley is pulled by wire and the college use the electric transport to the work Zone</li> <li>• When the personnel are at the work zone, they either work on their knees, if the work is close to the bottom of the tunnel, or they site on the trolley if the work is placed higher.</li> </ul> <p><b>Dismantling off the intermediate stations</b> The dismantling process of the intermediate station commences once the Tunnel Boring Machine (TBM) has arrived at and been removed from the end shaft. Under these conditions, the tunnel attains unrestricted airflow, with no physical obstructions impeding movement, and two available exits providing safe egress routes. To facilitate the removal of equipment such as trolleys during dismantling, hydraulic winches may be installed at both the start and end shafts. These winches enable controlled pulling of the trolley in both directions, ensuring efficient and safe handling of heavy components within the tunnel environment.</p> <ul style="list-style-type: none"> <li>• The personnel remove cylinders from the bottom and sides first, by lifting them with a chain hoist. This chain hoist is fixed to the cylinder in the top. This work is performed from the knees.</li> <li>• When the cylinders are removed from the bottom and sides and placed on the trolley, the trolley is pulled out to the shaft and emptied.</li> <li>• The trolley is now loaded with pallets, so the pallets height, is about 30cm from top pipe (ID)</li> <li>• The trolley is now pushed in under the intermediate station cylinders, and the top cylinders is dismantled, and falls 30 cm down on the pallet, this work can be performed by personnel sitting on a chair.</li> <li>• When all the cylinders a removed, the intermediate station is pushed together, with the main jacking cylinders in the shaft.</li> </ul> <p>There are also options to design a system yourself, where the cylinders are mounted on rolled plates, allowing 3-4 sections to be removed. With this solution, all cylinders are removed in 3 to 4 work steps, and there will be no grinding on the steel skirt that the intermediate station consists of</p>
6		<p><b>Repair in the tunnel (Installation of a rubbering in the pipes, closing bentonite holes ex.</b> The Tunnel Boring Machine (TBM) has successfully arrived at and been removed from the end shaft, and the slurry booster pumps and other equipment have likewise been extracted from the tunnel. As a result, unobstructed airflow is now established within the tunnel, with all obstacles cleared and two accessible exits available. To facilitate the movement of trolleys during subsequent operations, hydraulic winches have been installed at both the start and end shafts. These winches allow for controlled and safe towing of the trolley in both directions, thereby enhancing operational efficiency and safety within the tunnel environment. The work positions will be the same in all work scenarios.</p> <ul style="list-style-type: none"> <li>• Personnel drive to the work zone, using the electric transports.</li> <li>• The trolley is pulled in loaded with tools and materials, for the work assignment</li> <li>• Personnel will work eighter on their knees or sitting on the trolley.</li> </ul>

# Appendix ...

	Machine operations	Tunnel operations
7		<p><b>Dismantling equipment in the tunnel. Pipes, cables, closing bentonite holes ex.</b></p> <p>The Tunnel Boring Machine (TBM) has successfully arrived and been removed from the end shaft, and the soil cart been extracted from the tunnel. As a result, unobstructed airflow is now established within the tunnel, with all obstacles cleared and two accessible exits available.</p> <p>To facilitate the movement of trolleys during subsequent operations, hydraulic winches have been installed at both the start and end shafts. These winches allow for controlled and safe towing of the trolley in both directions, thereby enhancing operational efficiency and safety within the tunnel environment.</p> <ul style="list-style-type: none"> <li>• Personnel drive to the work zone, using the electric transports.</li> <li>• The trolley is placed next to ex. hose that need to be dismantled, a person is standing on each side of the trolley</li> <li>• The personnel now lift the hose down from the rack and on the trolley.</li> <li>• When the trolley is loaded, personnel use the telephone installed at the intermedia station, to call personnel placed in the shaft. The load is pull out to the shaft.</li> <li>• When the personnel need to dismantle heavy equipment like electric cables, the cables is taken down 3-5meters at a time and put on the trolley. At this way, the workers is lifting a minimum.</li> </ul> <p>When the equipment is getting to heavy to lift by hand, the personnel will use eighter a chain hoist mounted I the top af the tunnelpipe or a customized, electric crane mounted on the undercarriage af the trolley.</p>
8		<p><b>Dämmer/ grouting</b></p> <p>Upon completion of the tunneling process, the majority of the equipment within the tunnel is removed. One critical step in the finalization phase involves stabilizing the overcut surrounding the tunnel pipe. This stabilization is achieved by injecting grout material, specifically dämmer, into the overcut through bentonite injection nozzles. Bentonite pipes are installed throughout the tunnel at regular intervals, typically with every third pipe designated as a bentonite pipe. Each bentonite pipe is equipped with approximately three bentonite nozzles positioned along the circumference of the pipe to ensure even distribution of grout. The standard locations of these nozzles within the pipe are at approximately the 2 o'clock, 5 o'clock, and 7 o'clock positions. This systematic injection of dämmer through the bentonite nozzles plays a vital role in reinforcing the soil around the tunnel lining, thereby enhancing the structural stability and long-term integrity of the tunnel.</p> <p>The work processes for this work assignment can be performed by this following steps.</p> <ul style="list-style-type: none"> <li>• The automatic bentonite system is dismantled, leaving only bentonite nozzles.</li> <li>• Personnel in the tunnel connect a 1 inch rubber hose to the bentonite nozzle. This hose relates to the main bentonite line, which was previously used.</li> <li>• The tunnel staff contact the staff who mix and control the pumping of Dämmer. Pumping is initiated.</li> <li>• The staff in the tunnel make sure the overcut is filled with Dämmer when the external pressure in the overcutter is sufficient. This is done visually via a pressure gauge, which is mounted on the 1inch hose</li> <li>• When the overcut is filled, the 1inch hose is removed and mounted on the next bentonite nozzle and work processes are started again.</li> <li>• When the entire tunnel section overcut is sufficiently filled, the remaining pipes are dismantled. <i>See Dismantling equipment in the tunnel. Pipes, cables, closing bentonite holes ex.</i></li> </ul>

# Branchevejledning



  
**NoDig Infra**  
Opgravningsfrie løsninger